

GH/EH 675 Displacement Pump

For professional use only.

Not approved for use in explosive atmosphere or hazardous locations.

For portable airless spraying of architectural paints and coatings.

Models: 17U996

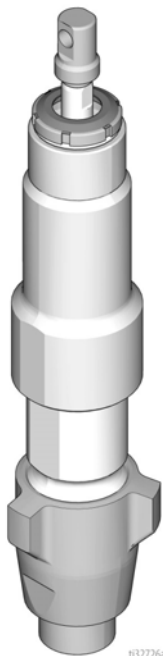

t132726a



Important Safety Instructions

Read all warnings and instructions in this manual and related manuals.
Be familiar with the controls and the proper usage of the equipment.
Save these instructions.

*Use only genuine Graco replacement parts.
The use of non-Graco replacement parts may void warranty.*





Table of Contents

Table of Contents

Warnings	3
Trigger Lock	4
Pressure Relief Procedure	4
Disassemble Pump	6
Assemble Pump	8
Notes	11
Parts Diagram	12
Parts List	13
Throat Packing Adjustment	14
Graco Standard Warranty	15
Graco Information	16

Warnings

The following warnings are for the setup, use, grounding, maintenance, and repair of this equipment. The exclamation point symbol alerts you to a general warning and the hazard symbols refer to procedure-specific risks. When these symbols appear in the body of this manual or on warning labels, refer back to these Warnings. Product-specific hazard symbols and warnings not covered in this section may appear throughout the body of this manual where applicable.

 WARNING	
	<p>SKIN INJECTION HAZARD</p> <p>High-pressure spray is able to inject toxins into the body and cause serious bodily injury. In the event that injection occurs, get immediate surgical treatment.</p> <ul style="list-style-type: none"> • Do not aim the gun at, or spray any person or animal. • Keep hands and other body parts away from the discharge. For example, do not try to stop leaks with any part of the body. • Always use the nozzle tip guard. Do not spray without nozzle tip guard in place. • Use Graco nozzle tips. • Use caution when cleaning and changing nozzle tips. In the case where the nozzle tip clogs while spraying, follow the Pressure Relief Procedure for turning off the unit and relieving the pressure before removing the nozzle tip to clean. • Equipment maintains pressure after power is shut off. Do not leave the equipment energized or under pressure while unattended. Follow the Pressure Relief Procedure when the equipment is unattended or not in use, and before servicing, cleaning, or removing parts. • Check hoses and parts for signs of damage. Replace any damaged hoses or parts. • This system is capable of producing 6750 psi. Use Graco replacement parts or accessories that are rated a minimum of 6750 psi. • Always engage the trigger lock when not spraying. Verify the trigger lock is functioning properly. • Verify that all connections are secure before operating the unit. • Know how to stop the unit and bleed pressure quickly. Be thoroughly familiar with the controls.
	<p>PRESSURIZED ALUMINUM PARTS HAZARD</p> <p>Use of fluids that are incompatible with aluminum in pressurized equipment can cause serious chemical reaction and equipment rupture. Failure to follow this warning can result in death, serious injury, or property damage.</p> <ul style="list-style-type: none"> • Do not use 1,1,1-trichloroethane, methylene chloride, other halogenated hydrocarbon solvents or fluids containing such solvents. • Do not use chlorine bleach. • Many other fluids may contain chemicals that can react with aluminum. Contact your material supplier for compatibility.
	<p>PERSONAL PROTECTIVE EQUIPMENT</p> <p>Wear appropriate protective equipment when in the work area to help prevent serious injury, including eye injury, hearing loss, inhalation of toxic fumes, and burns. This protective equipment includes but is not limited to:</p> <ul style="list-style-type: none"> • Protective eye wear, and hearing protection. • Respirators, protective clothing, and gloves as recommended by the fluid and solvent manufacturer.
	<p>CALIFORNIA PROPOSITION 65</p> <p>This product contains a chemical known to the State of California to cause cancer, birth defects or other reproductive harm. Wash hands after handling.</p>

Trigger Lock

Trigger Lock

Always engage the trigger lock when sprayer is stopped to prevent the gun from being triggered accidentally by hand or if dropped or bumped.

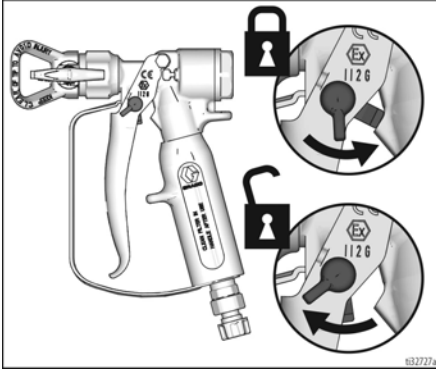

1. Engage trigger lock.

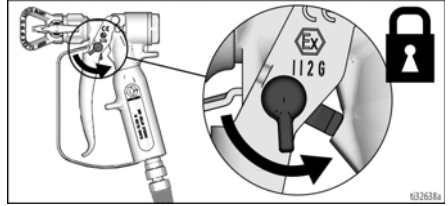

2. If applicable, turn electric motor ON/OFF switch to **OFF** position. Wait 7 seconds for power to dissipate.

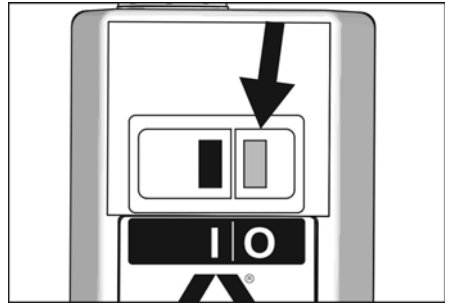

3. Unplug power cord or shut engine off.

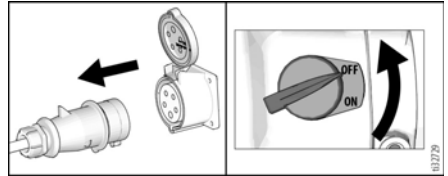

4. Disengage trigger lock.

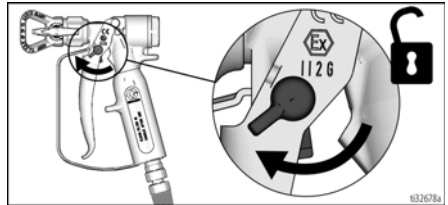

Pressure Relief Procedure

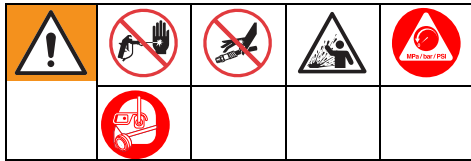

This equipment stays pressurized until pressure is manually relieved. To help prevent serious injury from pressurized fluid, such as skin injection, splashed fluid and moving parts, follow the **Pressure Relief Procedure** whenever sprayer is stopped and before sprayer is cleaned or checked, and before equipment is serviced.

5. Hold a metal part of the gun firmly to a grounded metal pail. Trigger the gun to relieve pressure.

Solvent and oil-based fluids: follow local code. Use only conductive metal pails, placed on a grounded surface such as concrete.

Do not place pail on a non-conductive surface such as paper or cardboard which interrupts grounding continuity.

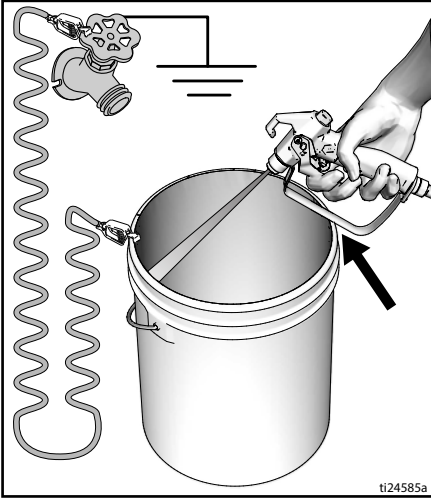

6. Engage trigger lock.

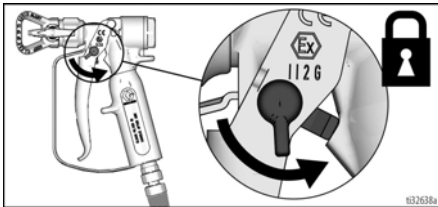

7. Open any fluid drain valves in system. Leave drain valves open until ready to spray again.

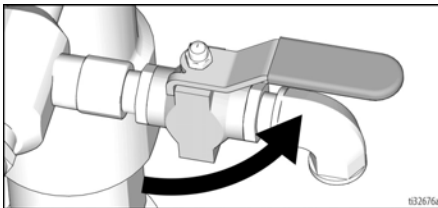

8. Remove pin then remove pump.

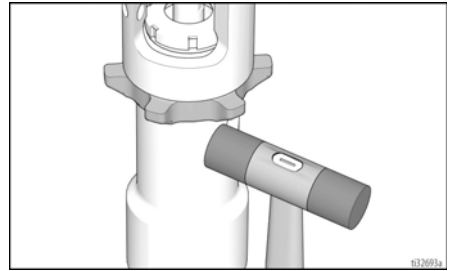
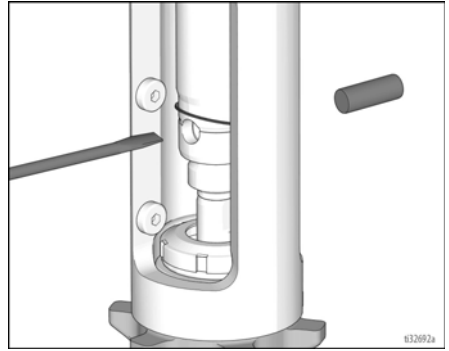

Disassemble Pump

Disassemble Pump

1. Remove Pump Rod Adapter.

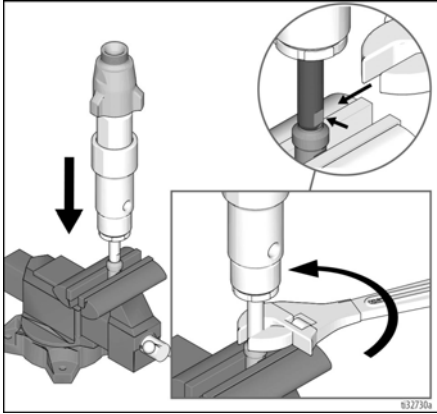

2. Unscrew cylinder from intake valve.

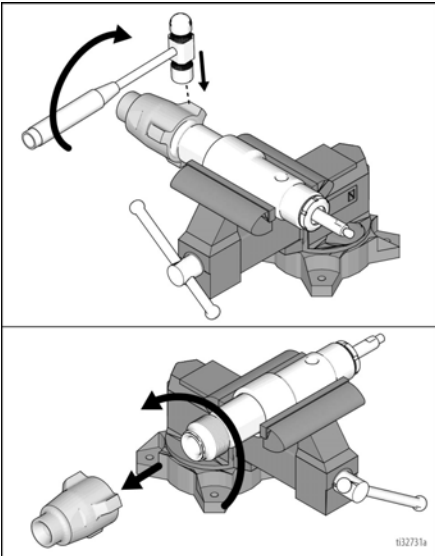

3. Loosen and remove packing nut.

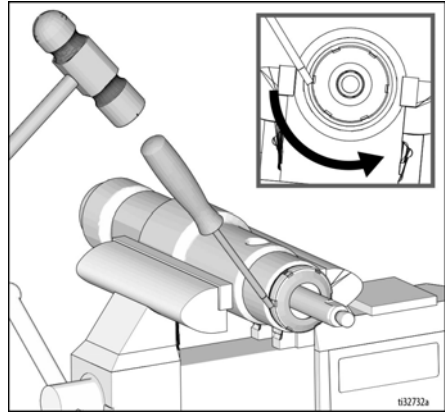

4. Tap piston rod out of cylinder with a plastic hammer being careful of the threads. Use a thin, soft rod if necessary.

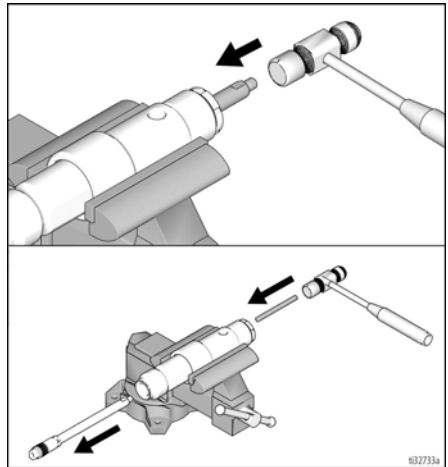

Do not clean or wipe the piston valve threads. Cleaning the piston valve threads could destroy the special sealing patch and cause the piston valve to come loose during operation, causing a pump burst and possible serious bodily injury.

Disassemble Pump

5. Unscrew piston valve from piston rod.

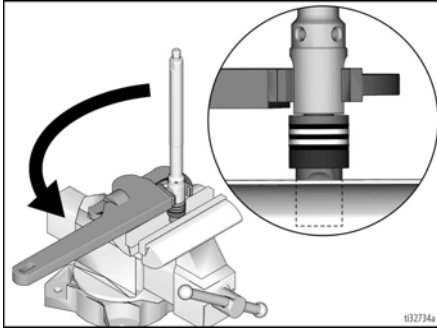

6. Remove piston from displacement rod.
Clean and inspect parts.

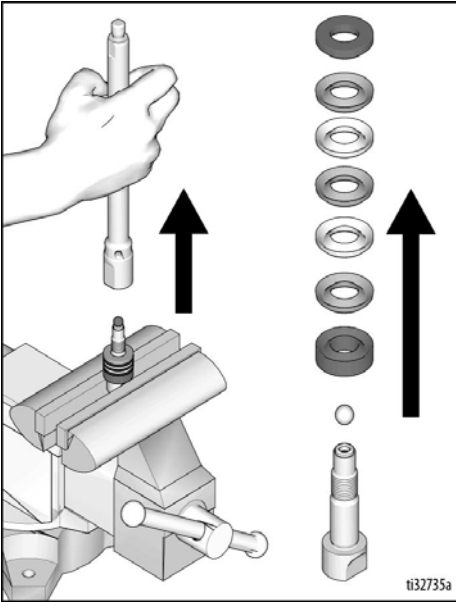

7. Remove and discard throat packing and glands from the cylinder.

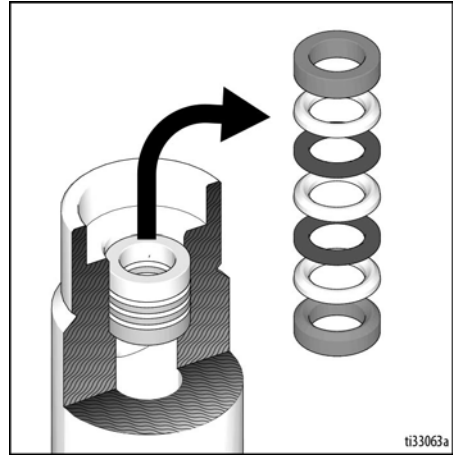

Assemble Pump

Assemble Pump

1. If applicable, soak leather packings in SAE 30W oil for one hour before assembly.

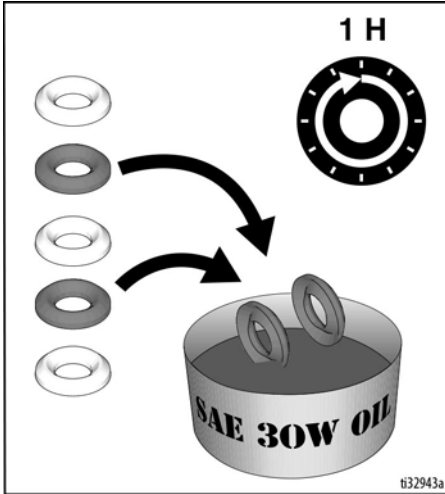

2. Assemble packings and ball to piston and piston rod.

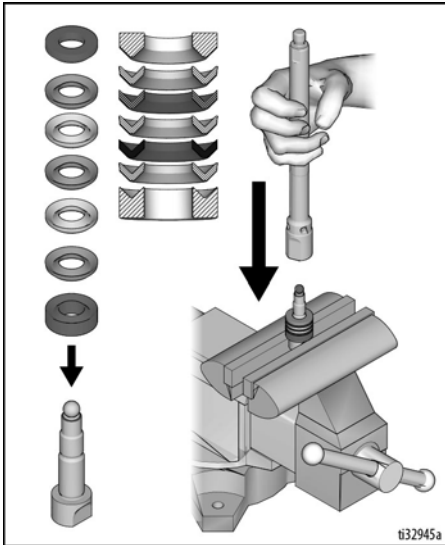

3. Torque to 85 ± 5 ft-lb (115 ± 7 N•m).

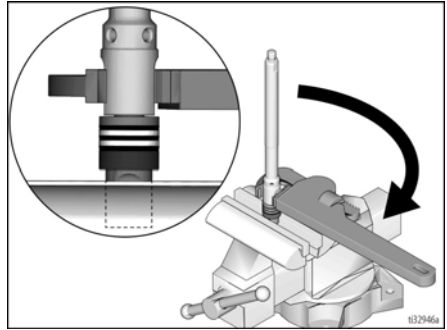

4. Assemble throat packings and place in pump cylinder.

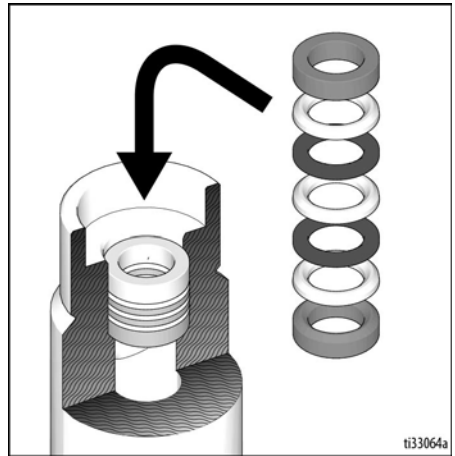

Assemble Pump

5. Apply liberal amounts of grease or oil to piston packings. Grease top inch or two of piston rod that will go through the cylinder throat packings.

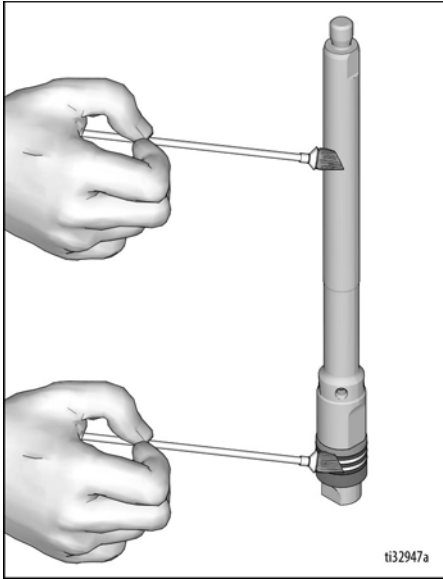

6. Gently guide displacement rod up through throat packings. Tap bottom of piston valve as necessary with a leather or plastic hammer.

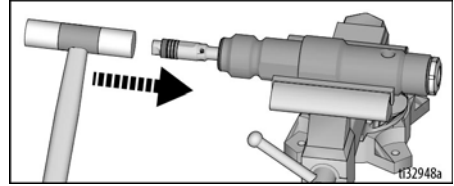

7. Grease o-ring and place on outside diameter ring groove.

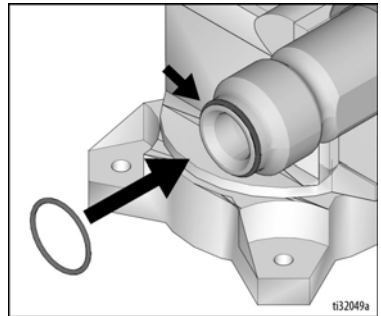

8. Clean seat thoroughly. Reassemble intake valve with a seat, ball, and new o-ring. Seat may be flipped over and used on other side.

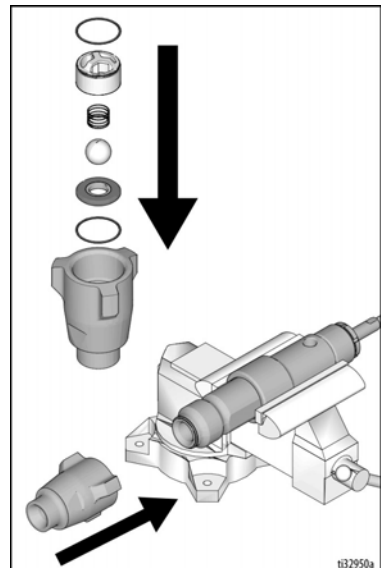

Assemble Pump

9. Torque foot valve to 290 ± 10 ft-lb (393 ± 14 N•m).

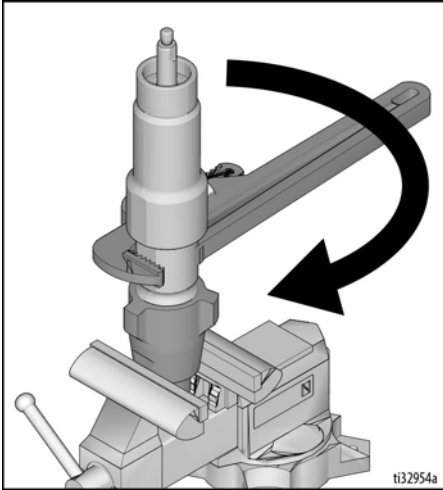

11. Install pump rod adapter, torque to 35 ± 5 ft-lbs (47 ± 7 N•m)

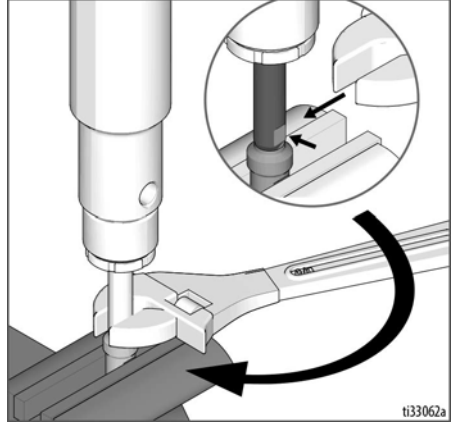

10. Install O-ring and Packing Nut. Torque packing nut to 25 ± 5 ft-lbs (34 ± 7 N•m).

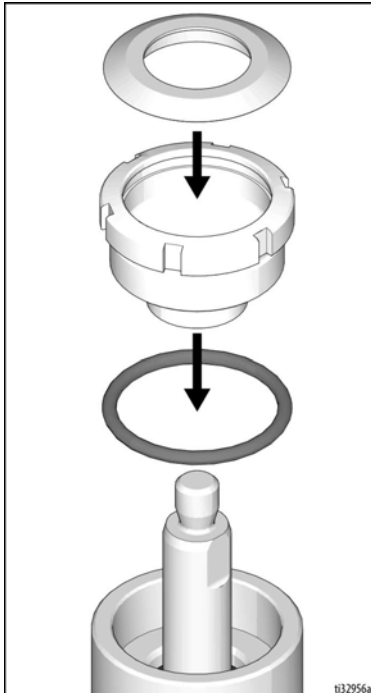

12. Storage

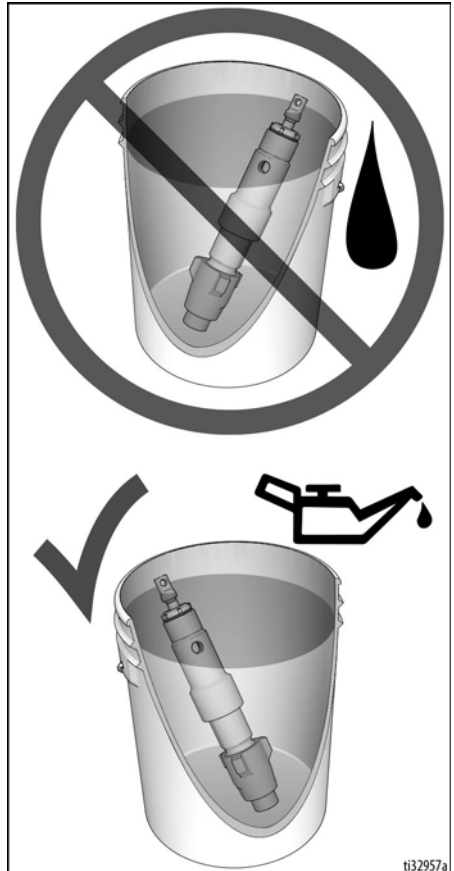

Parts Diagram

Parts Diagram

Ref.	Torque
1	35 ± 5 ft-lb (47 ± 7 N•m)
2	290 ± 10 ft-lb (393 ± 4 N•m)
3	85 ± 5 ft-lb (115 ± 7 N•m)
4	Soak in SAE 30w oil for 1 hour prior to assembly
5	Apply ThreadLocker

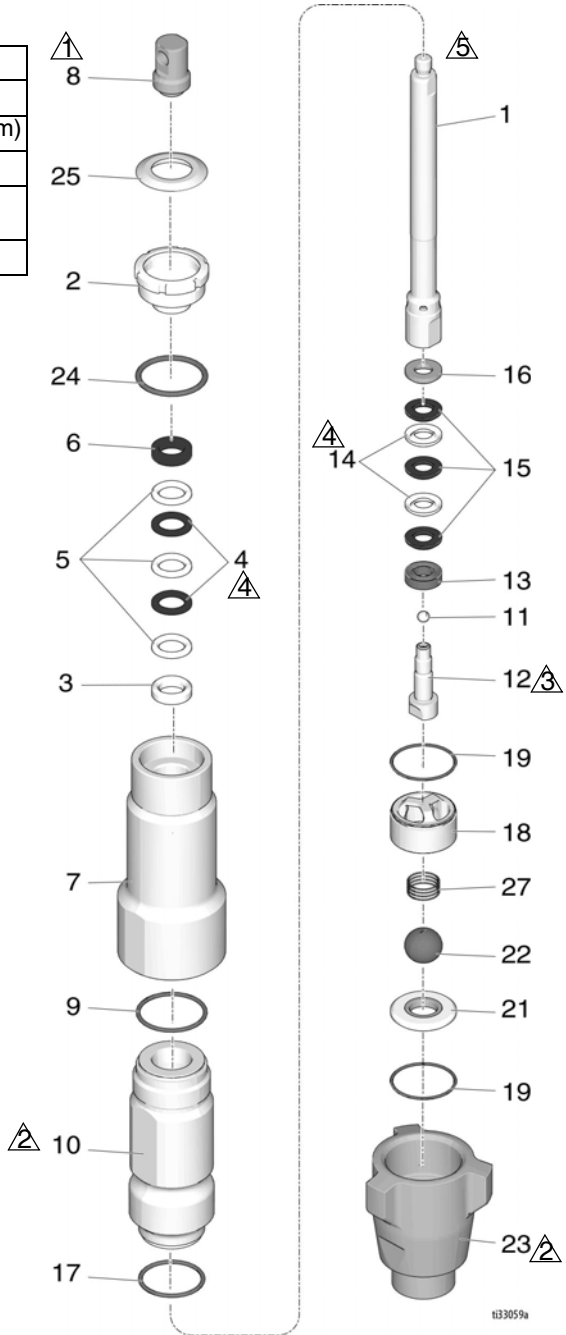

1133059a

Parts List

Ref	Part	Description	Qty
001+	17V630	ROD, displacement	1
002	17S991	NUT, packing	1
003*	16D490	GLAND, packing, male, throat	1
004*	17V024	PACKING, vee, leather	2
005*	17V207	PACKING, vee, blue	3
006*	16D484	GLAND, packing, female, throat	1
007	17S981	HOUSING, outlet, pump	1
008+	17V630	ADAPTER, rod	1
009*	109205	PACKING, o-ring, PTFE	1
010	17V631	CYLINDER, pump	1
011	17R145	BALL, .3125	1
012	17V632	VALVE, piston, assembly	1
013*	16D481	GLAND, packing, female, piston	1
014*	17V023	PACKING, vee, leather	2
015*	17V206	PACKING, vee, blue	3
016*	17V961	GLAND, packing, male, piston	1
017*▲	124169	PACKING, o-ring, 129	1
018	16D472	GUIDE, ball, (1.000")	1
019▲	108822	PACKING, o-ring, PTFE	2
021▲	15F665	SEAT, (1.000" BALL)	1
022▲	107167	BALL, SST	1
023	15F667	HOUSING, inlet	1
024*	157195	PACKING, o-ring, buna-n	1
025*	112590	PLUG, throat seal	1
027▲	124007	SPRING, compression	1

▲ Included in Repair Kit 17U998

+ Included in Repair Kit 17V630

* Included in Repair Kit 17U997

Throat Packing Adjustment

When pump packings begin to leak after much use, perform **Pressure Relief Procedure**, page 4, and tighten packing nut down until leakage stops or lessens. This allows approximately 100 gallons of additional operation before a repacking is required. Packing nut can be tightened without o-ring removal.

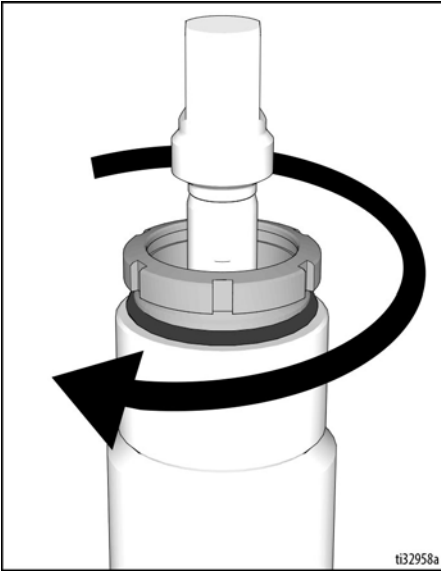

Graco Standard Warranty

Graco warrants all equipment referenced in this document which is manufactured by Graco and bearing its name to be free from defects in material and workmanship on the date of sale to the original purchaser for use. With the exception of any special, extended, or limited warranty published by Graco, Graco will, for a period of twelve months from the date of sale, repair or replace any part of the equipment determined by Graco to be defective. This warranty applies only when the equipment is installed, operated and maintained in accordance with Graco's written recommendations.

This warranty does not cover, and Graco shall not be liable for general wear and tear, or any malfunction, damage or wear caused by faulty installation, misapplication, abrasion, corrosion, inadequate or improper maintenance, negligence, accident, tampering, or substitution of non-Graco component parts. Nor shall Graco be liable for malfunction, damage or wear caused by the incompatibility of Graco equipment with structures, accessories, equipment or materials not supplied by Graco, or the improper design, manufacture, installation, operation or maintenance of structures, accessories, equipment or materials not supplied by Graco.

This warranty is conditioned upon the prepaid return of the equipment claimed to be defective to an authorized Graco distributor for verification of the claimed defect. If the claimed defect is verified, Graco will repair or replace free of charge any defective parts. The equipment will be returned to the original purchaser transportation prepaid. If inspection of the equipment does not disclose any defect in material or workmanship, repairs will be made at a reasonable charge, which charges may include the costs of parts, labor, and transportation.

THIS WARRANTY IS EXCLUSIVE, AND IS IN LIEU OF ANY OTHER WARRANTIES, EXPRESS OR IMPLIED, INCLUDING BUT NOT LIMITED TO WARRANTY OF MERCHANTABILITY OR WARRANTY OF FITNESS FOR A PARTICULAR PURPOSE.

Graco's sole obligation and buyer's sole remedy for any breach of warranty shall be as set forth above. The buyer agrees that no other remedy (including, but not limited to, incidental or consequential damages for lost profits, lost sales, injury to person or property, or any other incidental or consequential loss) shall be available. Any action for breach of warranty must be brought within two (2) years of the date of sale.

GRACO MAKES NO WARRANTY, AND DISCLAIMS ALL IMPLIED WARRANTIES OF MERCHANTABILITY AND FITNESS FOR A PARTICULAR PURPOSE, IN CONNECTION WITH ACCESSORIES, EQUIPMENT, MATERIALS OR COMPONENTS SOLD BUT NOT MANUFACTURED BY GRACO. These items sold, but not manufactured by Graco (such as electric motors, switches, hose, etc.), are subject to the warranty, if any, of their manufacturer. Graco will provide purchaser with reasonable assistance in making any claim for breach of these warranties.

In no event will Graco be liable for indirect, incidental, special or consequential damages resulting from Graco supplying equipment hereunder, or the furnishing, performance, or use of any products or other goods sold hereto, whether due to a breach of contract, breach of warranty, the negligence of Graco, or otherwise.

Graco Information

For the latest information about Graco products, visit www.graco.com.

For patent information, see www.graco.com/patents.

TO PLACE AN ORDER, contact your Graco distributor or call 1-800-690-2894 to identify the nearest distributor.

All written and visual data contained in this document reflects the latest product information available at the time of publication.

Graco reserves the right to make changes at any time without notice.

Original instructions. This manual contains English. MM 3A5443

Graco Headquarters: Minneapolis

International Offices: Belgium, China, Japan, Korea

GRACO INC. AND SUBSIDIARIES • P.O. BOX 1441 • MINNEAPOLIS MN 55440-1441 • USA

Copyright 2014, Graco Inc. All Graco manufacturing locations are registered to ISO 9001.

www.graco.com
Revision B, May 2019